

Weather Station Compact WSC11

Short - Instruction for Use

4.9056.1x.x0x, 4.9056.10.701, 4.9056.10.801

from software version V4.08 Status: 05/2024



Dok. No. 021948/05/24

THE WORLD OF WEATHER DATA

Safety Instructions

- Before operating with or at the device/product, read through the operating instructions. This manual contains instructions which should be followed on mounting, start-up, and operation. A non-observance might cause:
 - failure of important functions
 - endangerment of persons by electrical or mechanical effect
 - damage to objects
- Mounting, electrical connection and wiring of the device/product must be carried out only by a qualified technician who is familiar with and observes the engineering regulations, provisions and standards applicable in each case.
- Repairs and maintenance may only be carried out by trained staff or **Adolf Thies GmbH & Co. KG**. Only components and spare parts supplied and/or recommended by **Adolf Thies GmbH & Co. KG** should be used for repairs.
- Electrical devices/products must be mounted and wired only in a voltage-free state.
- **Adolf Thies GmbH & Co KG** guarantees proper functioning of the device/products provided that no modifications have been made to the mechanics, electronics or software, and that the following points are observed:
 - All information, warnings and instructions for use included in these operating instructions must be taken into account and observed as this is essential to ensure trouble-free operation and a safe condition of the measuring system / device / product.
 - The device / product is designed for a specific application as described in these operating instructions.
 - The device / product should be operated with the accessories and consumables supplied and/or recommended by **Adolf Thies GmbH & Co KG** .
 - Recommendation: As it is possible that each measuring system / device / product may, under certain conditions, and in rare cases, may also output erroneous measuring values, it is recommended using redundant systems with plausibility checks for **security-relevant applications**.

Environment

- As a longstanding manufacturer of sensors Adolf Thies GmbH & Co KG is committed to the objectives of environmental protection and is therefore willing to take back all supplied products governed by the provisions of "*ElektroG*" (German Electrical and Electronic Equipment Act) and to perform environmentally compatible disposal and recycling. We are prepared to take back all Thies products concerned free of charge if returned to Thies by our customers carriage-paid.
- Make sure you retain packaging for storage or transport of products. Should packaging however no longer be required, please arrange for recycling as the packaging materials are designed to be recycled.



Documentation

- © Copyright **Adolf Thies GmbH & Co KG**, Göttingen / Germany
- Although these operating instructions have been drawn up with due care, **Adolf Thies GmbH & Co KG** can accept no liability whatsoever for any technical and typographical errors or omissions in this document that might remain.
- We can accept no liability whatsoever for any losses arising from the information contained in this document.
- Subject to modification in terms of content.
- The device / product should not be passed on without the/these operating instructions.

Table of contents

1	Device Versions	4
2	Installation and Selection of Installation Site	4
2.1	Selection of installation site	4
2.2	Mechanical Mounting.....	4
2.2.1	North Alignment	6
2.3	Electrical Mounting	6
2.3.1	Cable, Cable Preparation, Connector Installation	6
2.4	Connecting Diagram.....	8
2.4.1	Connection using 5-core cable 510023 / 510024 / 510197 optional accessory...	8
2.4.2	Connection using 8-core cable 509584 / 509585 optional accessory	9
3	Maintenance	9
4	LED Signals	10
5	Specifications.....	11
6	Dimensional Drawing	13
7	More Information / Documents as download	14

Figures

Figure 3: LED signals	10
-----------------------------	----

Short Instructions for use

These short instructions for use describe the installation of the instrument. The detailed instructions allow users to modify the factory settings to their needs via the serial interface of the Weather Station Compact WSC11.

Scope of supply

- 1 Weather Station Compact WSC11
- 1 Copy of the short instructions for uses

The instructions for use are available for download under the following link:

https://www.thiesclima.com/db/dnl/4.9056.1x.x0x_WSC11_eng.pdf

For assisting the parameter settings and/or special configurations there is our cost-free Device Utility Tool art.-no. 9.1700.81.000 available for download on our homepage. Please download the tool with following link.

Link: <https://www.thiesclima.com/de/Download/>

In the section "General", the program "Thies Device Utility".

1 Device Versions

Designation	Order No.	Output terminal	Data format	Operating voltage
WEATHER STATION COMPACT WSC11	4.9056.10.000	1 x RS485	Data in ASCII format (command interpreter: THIES)	18...30V DC 18...28V AC
WETTERSTATION COMPACT WSC11	4.9056.10.001	1 x RS485	Data in binary format (command interpreter: MODBUS RTU)	18...30V DC 18...28V AC
WETTERSTATION COMPACT WSC11	4.9056.10.701	Identical to 4.9056.10.001 with following special settings: ID10		
WETTERSTATION COMPACT WSC11	4.9056.10.801	Identical to 4.9056.10.001 with following special settings: BR=192, ID =30, TT=0, SH= 3001		
WETTERSTATION COMPACT WSC11 with: - Precipitation quantity and intensity - Weather condition	4.9056.11.001	1 x RS485	Data in binary format (command interpreter: MODBUS RTU)	18...30V DC 18...28V AC

2 Installation and Selection of Installation Site

Please note:

The working position of the COMPACT WSC11 Weather Station is horizontal (plug connection underneath).

During installation, de-installation, transport or maintenance of the COMPACT WSC11 Weather Station make sure that no water gets into the device and connector.

2.1 Selection of installation site

An exposed position should be selected for this site. Measurement properties should not be influenced by light reflections, cast shadows or the device being positioned in the lee of the wind. Protection against lightning and overvoltages should also be provided by the customer.

2.2 Mechanical Mounting

The intended installation of the Weather Station WSC11 requires the use of a pipe socket / pipe with an **outside diameter of $\leq 25\text{mm}$** . The **inside diameter must be $\geq 19\text{mm}$** to admit the connector and cable.

Tool:

Hexagon socket wrench SW2mm (socket wrench).

Procedure:

1. Push cable/plug connection through the bore hole of the mast, tube, bracket etc.
2. Put WSC11 on mast, tube.
3. Align WSC11 to "north". (**Procedure see chapter 4.2.1**).
4. Secure WSC11 by the M4- hexagon socket screw.

Attention:

The hexagon socket screw is to be tightened by max. 0.6Nm.

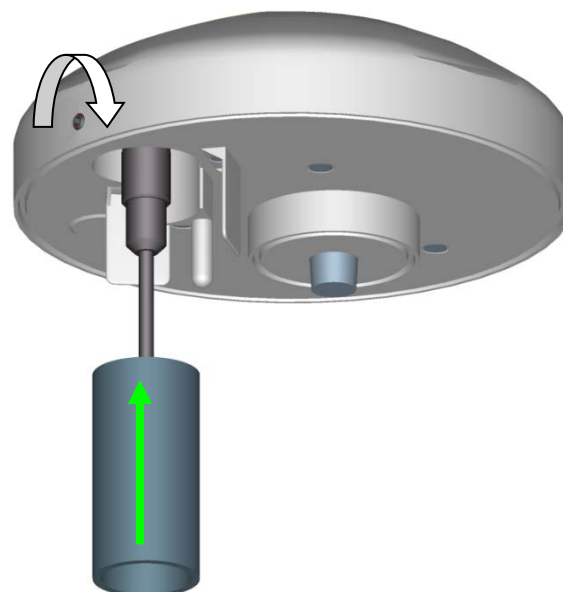

When using the **mounting angel article no. 509564** (see chapter accessories) the **guide angles must be removed**, see fig.

The mounting angle is not included in delivery.

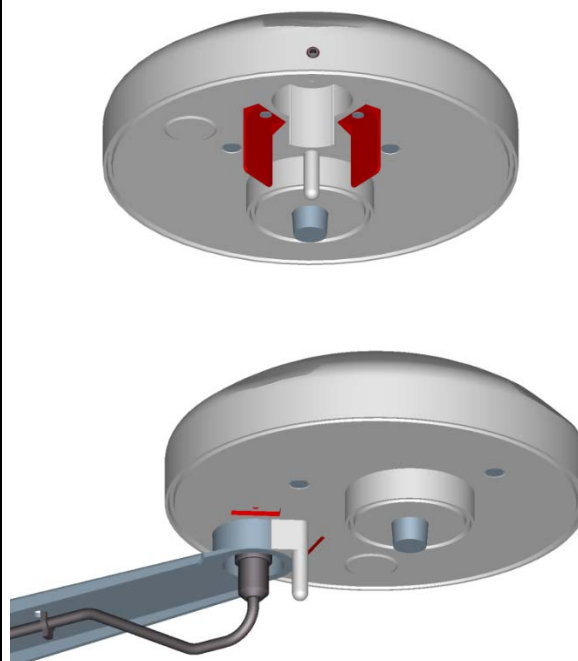

Remark: Tube and mounting angle are not included in delivery.

2.2.1 North Alignment

For the exact determination of wind- and brightness direction the WEATHER STATION COMPACT WSC11 must be mounted in **north alignment** (geographic north).

The hexagon socket screw **serves as north marking (N)**

Tool:

Hexagon socket wrench SW2mm (socket wrench).

Procedure:

1. Detect a prominent object in the surrounding area (tree, building etc.) in north direction by means of a compass.
2. Via the north marking (N) and an imaginary north-south axis the weather station is to be located on the prominent object.
3. Align weather station. The north marking must indicate to the geographic north.
4. In case of match the weather station is to be secured by an M4-hexagon socket screw.

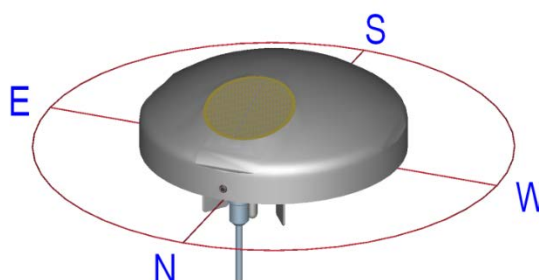

Attention:

The hexagon socket screw is to be tightened by max. 0.6Nm.

Remark:

With the north alignment by means of a compass, the local variation (deviation in direction of a compass needle from the true north direction) by interfering magnetic fields, and magnetic field influences by hardware and electric cable are to be considered.

2.3 Electrical Mounting

The COMPACT WSC11 Weather Station is equipped with a 7-pin plug for electrical connection. A cable socket (mating connector) is included in the scope of supply.

2.3.1 Cable, Cable Preparation, Connector Installation

The cable to be used for connection should have the following properties:
5 cores, core cross-section max. 0.14mm², cable diameter max. 5.0mm, resistant to ultraviolet rays, overall shielding.

Note:

A prepared connecting cable is available for the COMPACT WSC11 Weather Station as an optional accessory.

Cable socket, type: Binder, series 711

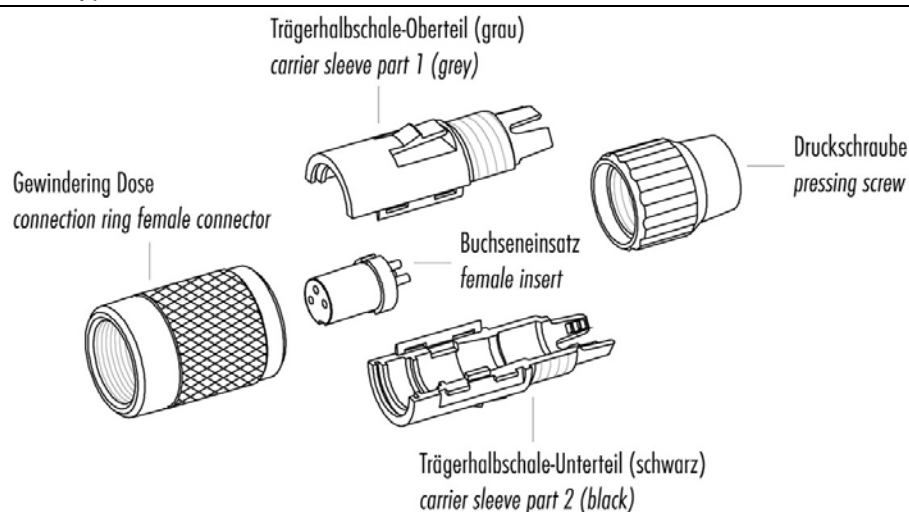

Achtung: max. Drehmoment des Gewinderings im Flanschsteckverbinder: 50cNm (handfest)
Attention: max. torque of ring nut in socket connector: 50cNm (manual adjustment)

Cable socket, type: Binder, series 712

1. Bead pressing screw, pinch ring, seal and snap bush to cable.
2. Dismantle cable to min. 10 and max 12 mm length.
3. Strip and solder single wires.
4. Screw snap bush with contact insert.
5. Push the assembled part into the coupling ring and screw the coupling ring with the snap bush.
6. Push seal and pinch ring into snap bush and tighten pressing screw.
7. Snap coupling ring onto snap bush.

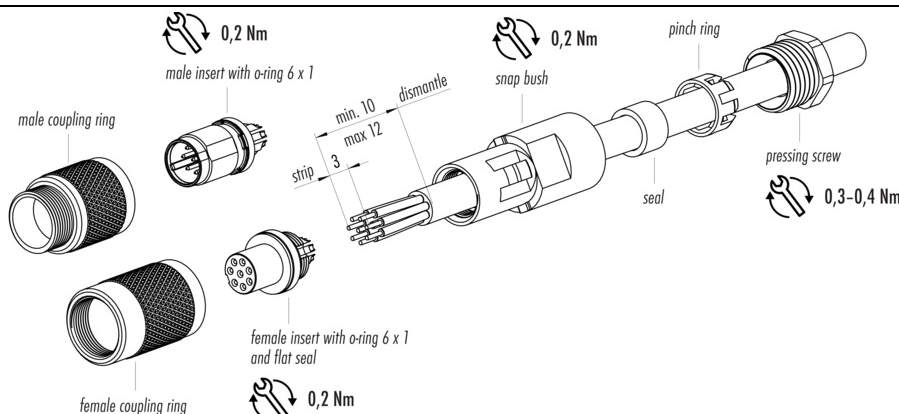

Attention:

The voltage drop on the cable must be taken into consideration with long cable connections, so that the supply voltage for the WEATHER STATION COMPACT WSC11 is guaranteed.

Calculation of the voltage drop on the cable. $U_{Ltg} = R_L \cdot I$; $R = 2 \cdot l \cdot \rho / A$; ρ (rho) = 0,018

Example: $I = 0,3A$, $A = 0,14mm^2$, $L = 100m$

$$R = 2 \cdot l \cdot \rho / A, \quad R = 25,7\Omega$$

$$U_{Ltg} = R_L \cdot I, \quad U_{Ltg} = 7,7V$$

2.4 Connecting Diagram

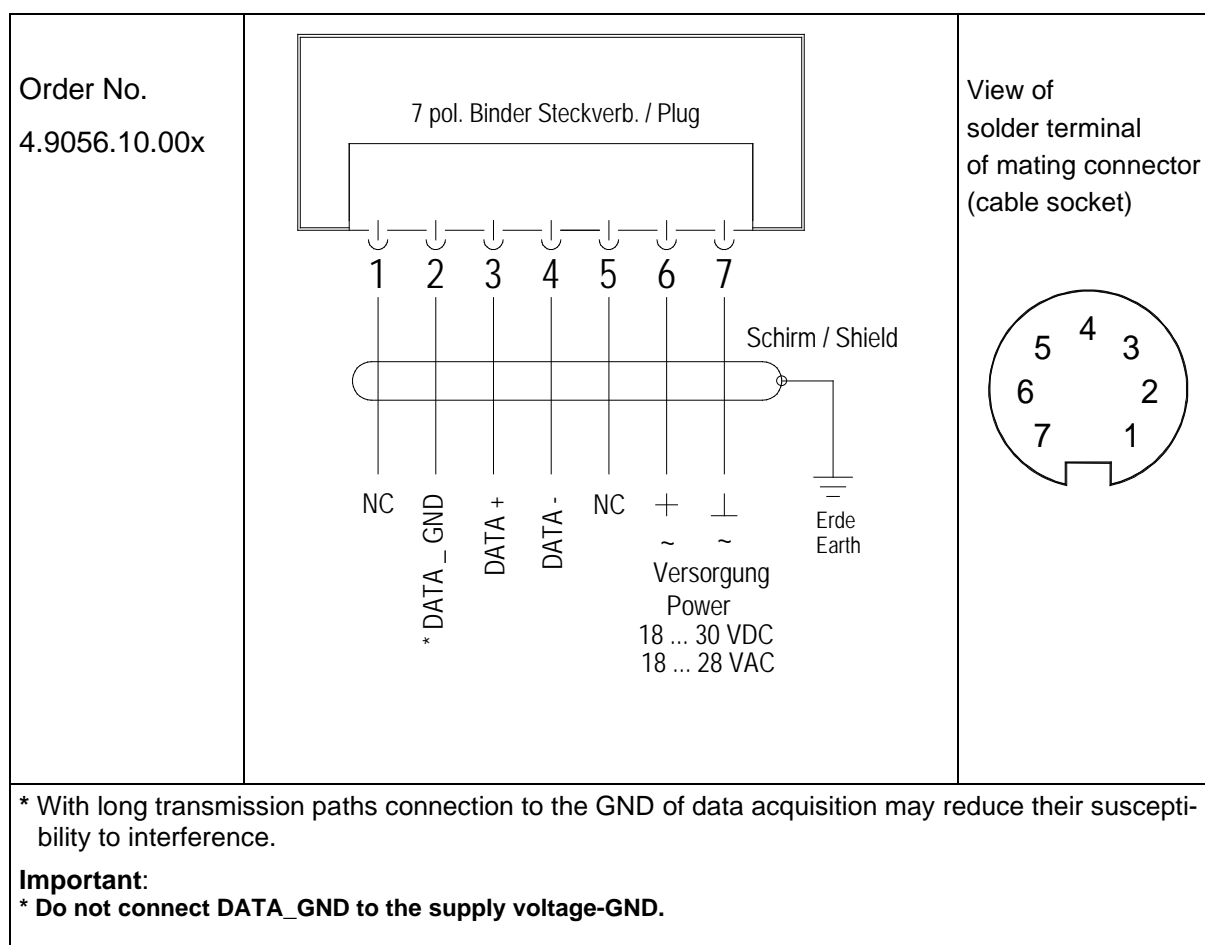

2.4.1 Connection using 5-core cable 510023 / 510024 / 510197 optional accessory

PIN	Core colour	Function
1		NC
2	WHITE	* DATA_GND
3	BROWN	DATA +
4	GREEN	DATA -
5		NC
6	YELLOW	+ power 18...30V DC / 18...28V AC
7	GRAY	- power 18...30V DC / 18...28V AC

Difference to part no. 509584/509585, 5 cores.

* With long transmission paths connection to the GND of data acquisition may reduce their susceptibility to interference.

Important:
* Do not connect DATA_GND to the supply voltage-GND.

2.4.2 Connection using 8-core cable 509584 / 509585 optional accessory

PIN	Core colour	Function
1	WHITE	NC
2	BROWN	* DATA _ GND
3	GREEN	DATA +
4	YELLOW	DATA -
5	GREY	NC
6	PINK	+ power 18...30V DC / 18...28V AC
7	BLUE	- power 18...30V DC / 18...28V AC
-	RED	NC

Difference to part no. 510023/510024, 8 cores, three not connected (NC).
 * With long transmission paths connection to the GND of data acquisition may reduce their susceptibility to interference.
Important:
 * Do not connect DATA_GND to the supply voltage-GND.

3 Maintenance

As the device does not have any moving parts, i.e. is not subject to wear during operation, only minimal servicing is required.

Depending on the location the instrument might pollute. The cleaning should be carried out by means of water and a soft cloth. Aggressive cleaning agents must not be used.

Please note:

During storage, installation, de-installation, transport or maintenance of the COMPACT WSC11 Weather Station make sure that no water gets into the device or connector.

We recommend the following procedure for humidity calibration:

1. Storage of the device for several hours at rather low humidity levels
2. Carrying out the calibration in accordance with DKD guideline 5-8 "Calibration of hygrometers for direct measurement of relative humidity"; Procedure A1, A2, B1 or B2
3. Consideration of the adjustment time also according to the DKD guideline 5-8 "Calibration of hygrometers for the direct recording of the relative humidity"

4 LED Signals

On the underside of the COMPACT WSC11 Weather Station there are 2 LEDs which are externally visible through the housing.

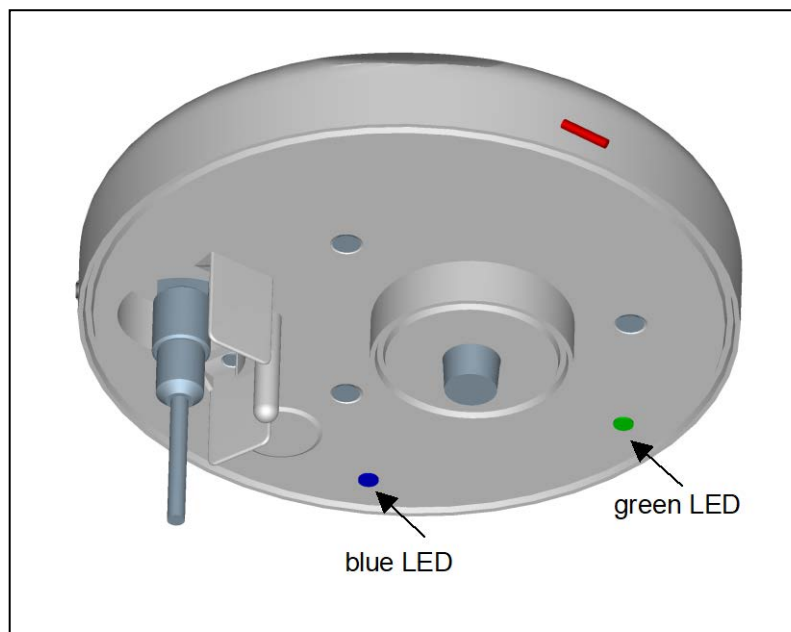
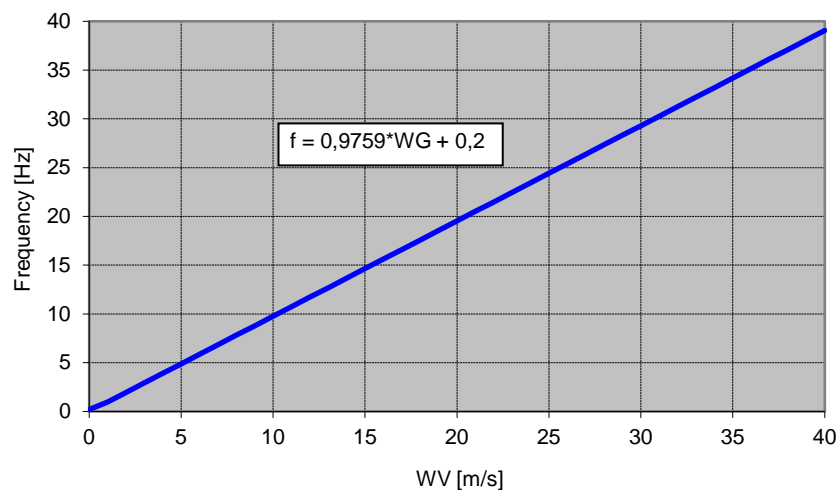

Figure 1: LED signals

If the Weather Station does not receive a command to query measured values for 3 seconds or longer, the green LED flashes at a frequency of 1Hz and signals its readiness for operation. If automatic telegram output is enabled (see **Command TT**), the green LED remains dark.

The flash frequency of the blue LED indicates the current wind speed (see **Command LC**)
The correlation between the flash frequency and wind speed is shown in the following figure:

Flash frequency of blue LED as a function of wind velocity



5 Specifications

Wind speed		
	Type	Thermal anemometer
	Measuring range	0 ... 40m/s
	Resolution	0.1m/s
	Accuracy	To 10m/s: ±1m/s (rms - mean over 360°) From 10m/s: ±5% (rms - mean over 360°)
Wind direction		
	Type	Thermal anemometer
	Measuring range	1 ... 360°
	Resolution	1°
	Accuracy with laminar incident flow	±10°
Brightness		
	Type	Silicon sensor
(north, east, south, west)	Measuring range	0 ... 150kLux
	Resolution	0.1kLux
	Accuracy	±3% (± 4.5kLux)
	Spectral range	475 ... 650nm
Twilight		
	Type	Silicon sensor
	Measuring range	0 ... 999Lux
	Resolution	1Lux
	Accuracy	±10Lux
Global irradiance		
	Type	Silicon sensor
	Measuring range	0 ... 1300W/m ²
	Resolution	1W/m ²
	Accuracy	±10% (± 130W/m ²)
	Spectral range	350 ... 1100nm
Precipitation		
	Type	Ceramics, capacitive value measurement, sensor area heated
	Measuring range	1 / 0 (precipitation yes/no)
	Measuring intensity	0...15mm/h
	Resolution	0,001mm/h
	Measuring quantity	0...999,999mm
	Resolution	0,001mm
	Thermal output, sensor dry, bedewing protection	0.1W
	Thermal output, sensor wet drying phase	1.1W

Temperature		
	Type	PT1000
	Measuring range	-30 ... +60°C
	Resolution	0.1°C
	Accuracy with wind speed >2m/s	±1°C (-5 ... +25°C)
Air pressure sensor		
	Type	Piezoresistive
	Measuring range	300 ... 1100hPa
	Resolution	0.01hPa
	Accuracy	±0.5hPa at 20°C
	Long-term stability	±0.1hPa / year
Humidity sensor		
	Type	CMOS capacitive
Relative humidity		
	Measuring range	0 ... 100% rel. humidity
	Resolution	0.1% rel. humidity
	Accuracy with wind speed >2m/s	±10% rel. humidity at 20°C
Absolute humidity		
	measuring range	0 ... 400g/m ³
	Resolution	0.01g/m ³
Dew-point temperature		
	Measuring range	-30 ... +60°C
	Resolution	0.1°C
Inside temperature of housing		
	Type	Silicon sensor
	Measuring range	-30 ... +60°C
	Resolution	0.1°C
	Accuracy	±2°C
Digital interface		
	Type	RS485
	Mode	Half-duplex mode
	Baud rate	1200, 2400, 4800, 9600 , 19200, 38400, 57600, 115200
	Data format	- ASCII (command interpreter: THIES) - Binary (command interpreter: MODBUS RTU)

General		
Operating voltage		18 ... 30VDC, 18 ... 28VAC
	Power consumption	120mA @ 24 V (max. 1,5A AC, max 0,5A DC)
Ambient conditions	Temperature range	-30 ... +60°C
	Humidity range	Non-condensing
To avoid false-positive Precipitation outputs, the setting HP=20 is recommended when used in humid and hot climates (RH>85% @ air temperature>35°C).		
GPS reception	GPS receiver with low power consumption, built-in RTC and antenna	
	Holding time of RTC (without voltage supply)	Approx. 3 days
Housing	Material	Polycarbonate
	Dimensions	See Dimension drawing
	Weight	0.22kg
	Type of protection	IP65 in working position
	Type of connection	7-pin plug connector

6 Dimensional Drawing

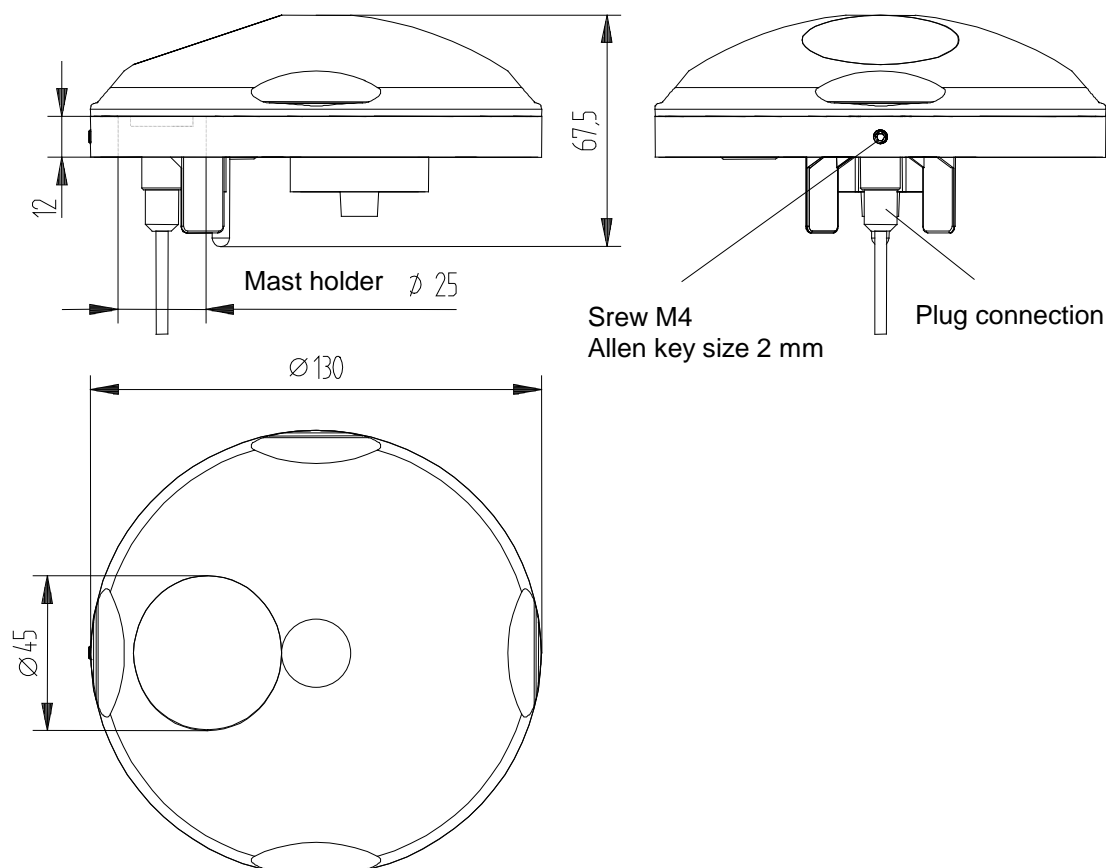

7 More Information / Documents as download

Further information can be found in the short instructions for use. These document and also the short instruction for use are available for download under the following links.

Short instruction for use

https://www.thiesclima.com/db/dnl/4.9056.1x.x0x_WSC11_eng_short.pdf

Instruction for Use

https://www.thiesclima.com/db/dnl/4.9056.1x.x0x_WSC11_eng.pdf

**Please contact us for your system requirements.
We advise you gladly.**

ADOLF THIES GMBH & CO. KG

Meteorology and environmental metrology
Hauptstraße 76 · 37083 Göttingen · Germany
Phone +49 551 79001-0 · Fax +49 551 79001-65
info@thiesclima.com



www.thiesclima.com